

Environmental conditions

Specification item	Value	Unit	Condition
Ambient temperature	-40...70	°C	
Max. allowable surface temperature	80	°C	
Storage temperature	-40...85	°C	
Relative humidity	5...95	%	Non-condensing
Suitable for outdoor luminaires	Yes		Built-in only

Lifetime

Specification item	Value	Unit	Condition
Lifetime	100,000	hours	At max. surface temperature, min. 90% survival rate

Product dimensions

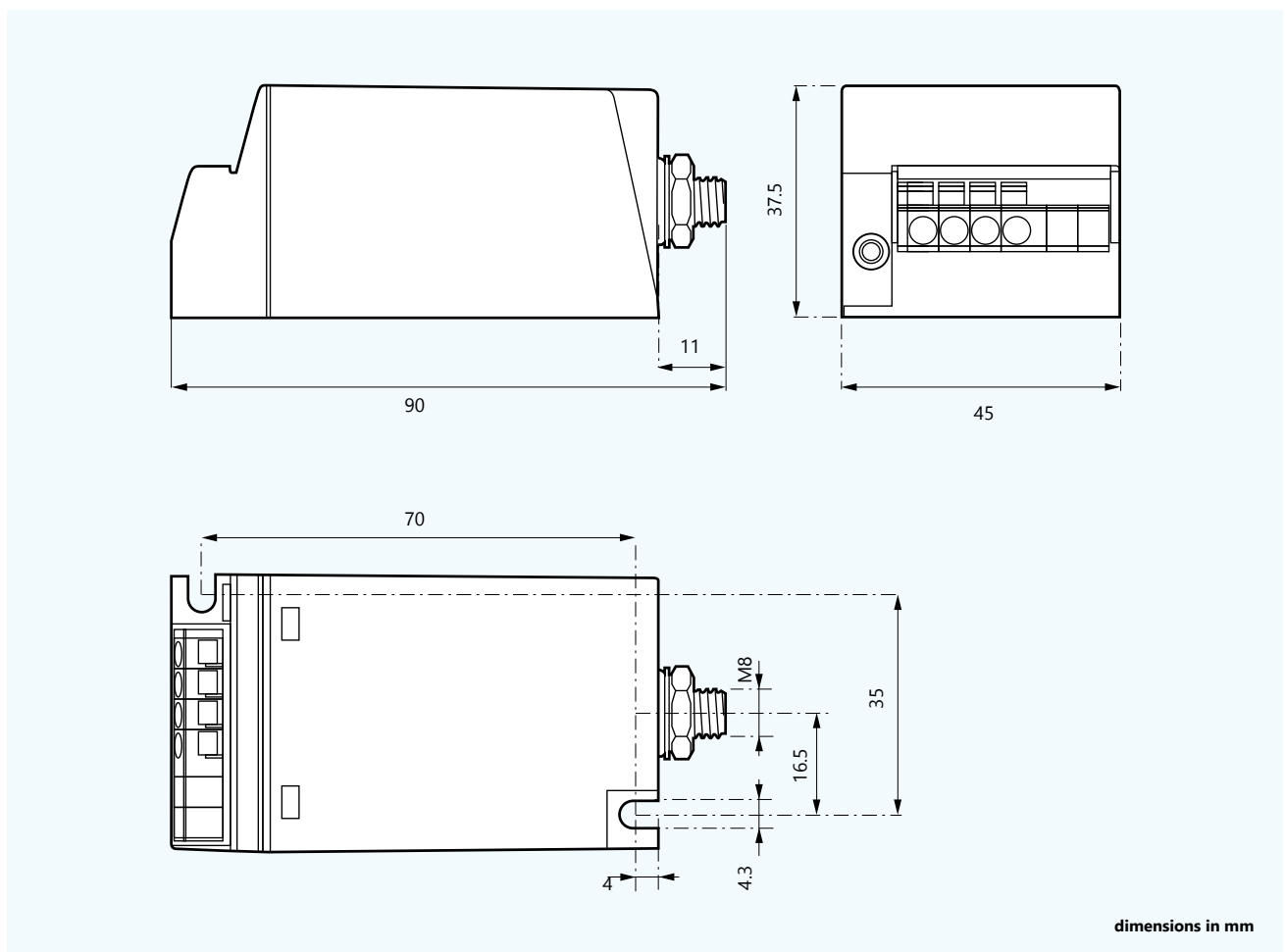

Specification item	Value	Unit
Mounting length	70	mm
Overall length	90	mm
Case Width	45	mm
Case Height	37.5	mm
Fixing hole diameter	M4	
Fixing screw type	M8	
Mounting torque M4 screw/M8 stud (max)	0.8	Nm
Weight	70	gr

Wiring

Specification item	Value	Unit	Condition
Connector type	Push-in		Single wire only
Wire diameter	0.5...2.5	mm ²	Solid and stranded
Wire strip length	10...11	mm	

Connection diagram and recommended wiring layout

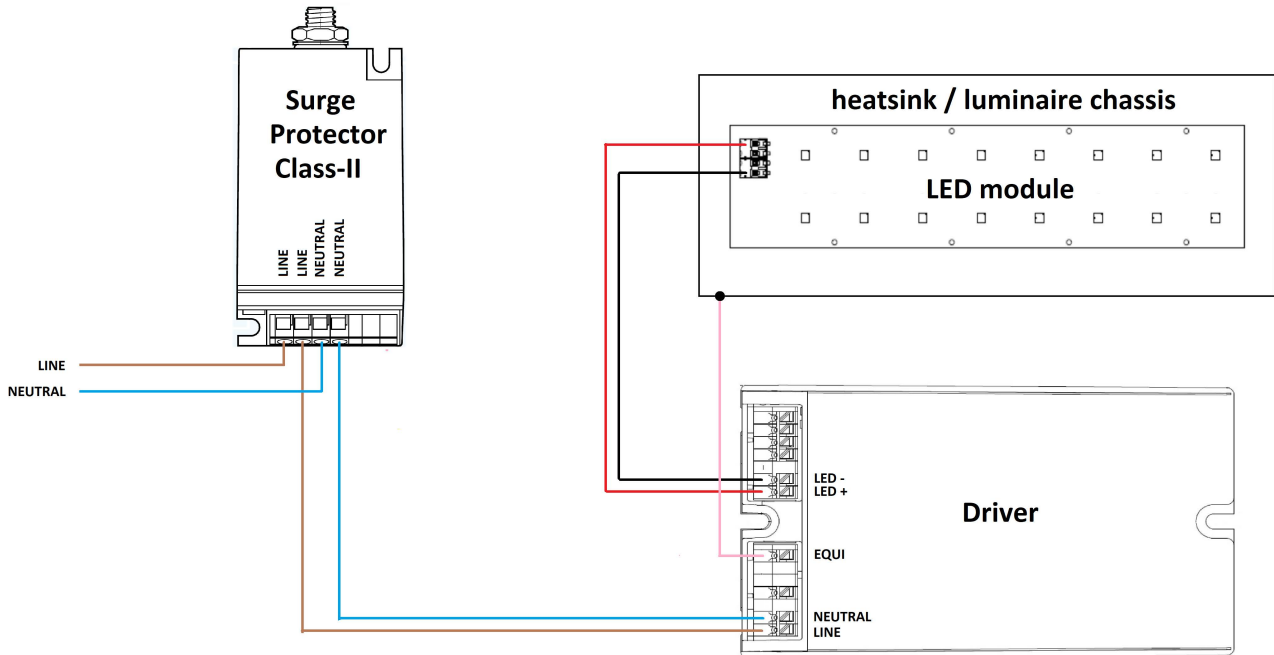

Electrical connections

Signal	Description	Color
LINE	Line connection	Black
LINE	Line connection	Black
NEUTRAL	Neutral connection	White
NEUTRAL	Neutral connection	White

System Disposal

We recommend that the Surge Protector is disposed of in an appropriate way at the end of its (economic) lifetime. The Surge Protector is in effect a normal piece of electronic equipment containing components that are currently not considered to be harmful to the environment. We therefore recommend that this part is disposed of as normal electronic waste, in accordance with local regulations.



©2019 Signify Holding, IBRS 10461, 5600 VB, NL. All rights reserved.

The information provided herein is subject to change without notice. Signify does not give any representation or warranty as to the accuracy or completeness of the information included herein and shall not be liable for any action in reliance thereon. The information presented in this document is not intended as any commercial offer and does not form part of any quotation or contract, unless otherwise agreed by Signify.

Philips and the Philips Shield Emblem are registered trademarks of Koninklijke Philips N.V. All other trademarks are owned by Signify Holding or their respective owners.

Date of release: March 22, 2019

www.philips.com/oem